

What are Hygienics?

Stainless Steel Hygienics is the name given to a range of tube and fittings used in applications requiring a clean and sanitary flow of liquids and where it is essential to avoid contamination of the products being carried.

These applications cover the food processing, beverage, biotech and pharmaceutical industries including breweries and dairies.

The applications are low pressure with a maximum of 150lbs.

The products are available in grades 304L and 316L.

The size range is from $\frac{3}{4}$ inch to 4 inch O/D plus there are some metric sizes to DIN Standards.

The tube and fittings are of welded construction with the internal bead rolled to flatten it and eliminate crevices, thus preventing interruptions to the flow and eliminating the risk of contamination or bug traps as well as facilitate easy cleaning.

The tube and fittings are offered with a choice of external finishes:

- Descaled
- Bright Annealed
- Dull Polished
- Semi-Bright or Bright Polished.

Hygienic tubes are manufactured to ASTM A270, DIN 11850, ISO2037 and BS 4825 Part 1.

Hygienic fittings are manufactured to BS4825 Parts 2 to 5. (EN20286)

Markings on the tube and fittings:

Tube and fittings with a bright annealed or polished finish will be unmarked.

CONTACT

Address:	Aldridge Warehouse No. 1 Wharf Approach Anchor Brook Industrial Park Aldridge Walsall WS9 8BX
Tel:	+44 (0)19 2245 3982
Email:	sales@durbinmetals.co.uk
Web:	www.durbinmetals.co.uk

REVISION HISTORY

Datasheet Updated	18 July 2019
-------------------	--------------

DISCLAIMER

This Data is indicative only and as such is not to be relied upon in place of the full specification. In particular, mechanical property requirements vary widely with temper, product and product dimensions. All information is based on our present knowledge and is given in good faith. No liability will be accepted by the Company in respect of any action taken by any third party in reliance thereon.

Please note that the 'Datasheet Update' date shown above is no guarantee of accuracy or whether the datasheet is up to date.

The information provided in this datasheet has been drawn from various recognised sources, including EN Standards, recognised industry references (printed & online) and manufacturers' data. No guarantee is given that the information is from the latest issue of those sources or about the accuracy of those sources.

Material supplied by the Company may vary significantly from this data, but will conform to all relevant and applicable standards.

As the products detailed may be used for a wide variety of purposes and as the Company has no control over their use; the Company specifically excludes all conditions or warranties expressed or implied by statute or otherwise as to dimensions, properties and/or fitness for any particular purpose, whether expressed or implied.

Advice given by the Company to any third party is given for that party's assistance only and without liability on the part of the Company. All transactions are subject to the Company's current Conditions of Sale. The extent of the Company's liabilities to any customer is clearly set out in those Conditions; a copy of which is available on request.

Hygienics

Introduction/Tube Range

Stainless Steel Hygienics is the name given to a range of tube and fittings used in applications requiring a clean and sanitary flow of liquids and where it is essential to avoid contamination of the products being carried. These applications cover the food processing, beverage, biotech and pharmaceutical industries including breweries and dairies.

- The applications are low pressure with a maximum of 150lbs.
- The products are available in grades 304L and-316L.
- The size range is from 1/2 inch to 4 inch O/D.
- The tube and fittings are of welded construction with the internal bead rolled to flatten it and eliminate crevices, thus preventing interruptions to the flow and eliminating the risk of contamination or bug traps as well as facilitate easy cleaning.
- The tube and fittings are offered with a choice of external finishes:
 - Descaled
 - Bright Annealed
 - Dull Polished
 - Semi-Bright or Bright Polished.

Manufacturing standards

- Hygienic tubes are manufactured to ASTM A270, DIN 11850, ISO 2037 and BS 4825 Part 1.
- Hygienic fittings are manufactured to BS 4825 Parts 2 to 5.

Markings on tube and fittings

Tube and fittings with a bright annealed or polished finish will be unmarked.

Range/Sizes - Tube

Sizes to ASTM A270

O/D	Wall		Weight
	in	swg	mm
3/4	16	1.63	0.70
1	16	1.63	0.99
1 1/2	16	1.63	1.51
2	16	1.63	1.88
2 1/2	16	1.63	2.49
3	16	1.63	3.01
4	16	1.63	4.03
4	14	2.03	4.98

Sizes to DIN 11850

O/D	Wall	Weight
	in	mm
1	1.5	0.90
1 1/2	1.5	1.38
2	1.5	1.85
2 1/2	1.5	2.34
3	1.5	2.81
4	2.0	5.02

Hygienics

Hygienic Bends and Tees - BS 4825 : Part 2



There are two types of bends and tees available, the Short type and Long type. For bends, the Short type simply comprises a 90° bend, while the Long type has a straight leg added at both ends. Tees have equivalent dimensions making them interchangeable. The straight leg of long type bends and tees was originally added to enable expanded type clamp and union parts to be fitted, but they are now widely used in all-welded installations.

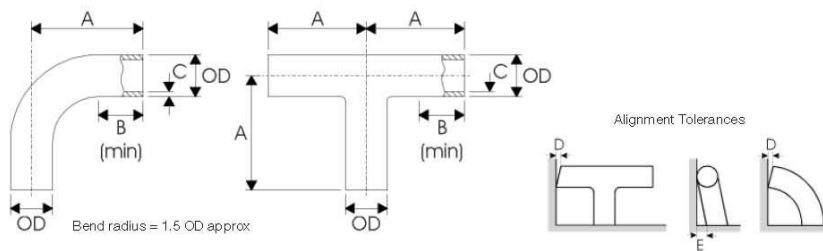

Dimensions and tolerances

OD	Short Type			Long Type			Max Deviation	
	A	B	C	A	B	C	D	E
mm	mm	mm	mm	mm	mm	mm	mm	mm
12.7	-	-	-	45	25	1.2	0.1	0.2
15.88	-	-	-	55	25	1.2	0.2	0.4
19.05	-	-	-	60	25	1.2	0.2	0.4
25.4	43.5	25	1.6	65	25	1.6 (or 1.2 ¹)	0.25	0.5
38.1	63.5	25	1.6	85	25	1.6 (or 1.2 ¹)	0.3	0.6
50.8	88.5	30	1.6	110	30	1.6 (or 1.2 ¹)	0.4	0.8
63.5	113.5	35	1.6	135	35	1.6	0.5	1.0
76.2	133.5	38	1.6	155	38	1.6	0.5	1.0
101.6	173.5	38	2.0	195	38	2.0	0.7	1.4

Notes

¹ The 1.2mm wall thickness is for use with expanded fittings.

• Length tolerances: +0.5mm, -0mm.

Hygienics

Clamp Fittings - BS 4825 : Part 3



Clamp fittings provide a crevice free joint and, depending on the clamp design, requires no tools for assembly or dismantling for cleaning. Provides quick method of regularly opening up a system and often has some kind of closure device such as a 'Triclover' clamp. Used where corrosion and contamination are particular hazards, as in the pharmaceutical industry. Also used in systems carrying warm semi-solids and viscous liquids, such as chocolate and tomato sauce, which must not cool in the line but tend to cause regular blockages.

Clamp fittings comprise four parts – two welding ferrules, a seal ring and a clamp. The ends of the tubes and/or fittings to be joined have a welding ferrule fitted by welding (or expansion on to expanded type parts if used). The joint is made by positioning the welding ferrules together, with a seal inserted between the faces, and then clamping the ferrules together. The clamp is not in contact with the contents of the pipe and may be made of any suitable material.

Assembly

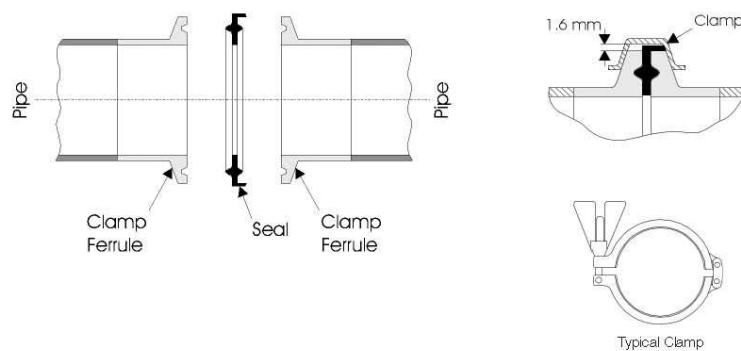

Hygienics

Clamp Fittings - BS 4825 : Part 3

Welding ferrule

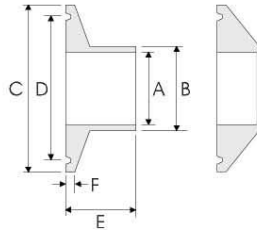

OD	A	B	C	D	E	F
mm	mm	mm	mm	mm	mm	mm
25.4	22.2	25.65	50.5	43.5	21.5	2.85
38.1	34.9	38.35	50.5	43.5	21.5	2.85
50.8	47.6	51.05	64.0	56.5	21.5	2.85
63.5	60.3	63.75	77.5	70.5	21.5	2.85
76.2	73.0	76.45	91.0	83.5	21.5	2.85
101.6	97.6	101.85	119.0	110.0	21.5	2.85

Seals

Two types of seal are defined in BS 4825, the first for use when a joint is to be frequently disconnected and the second for use in less frequently disconnected joints. The dimensions of both types are given below:

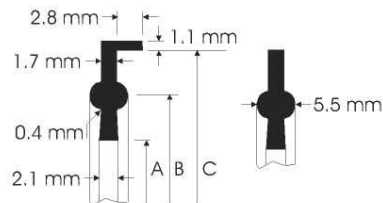

OD	A	B	C
mm	mm	mm	mm
25.4	22.8	43.5	50.5
38.1	35.5	43.5	50.5
50.8	48.2	56.5	64.0
63.5	60.5	70.5	77.5
76.2	73.2	83.5	91.0
101.6	97.8	110.0	119.0

Hygienics

IDF Unions - BS 4825 : Part 4



The International Dairy Federation, IDF, coupling provides a crevice free joint originally designed for applications where frequent dismantling for cleaning would not be necessary. They may be operated at pressures up to 1.6 MPa.

The Liner is machined and the Nitrile or EPDM Seal is a square section and is more substantial than the RJT. The IDF Union also has a thicker Nut than the RJT. It is machined rather than pressed and is considered easier to use.

Compared to the RJT, the IDF has a smoother and cleaner flow line that is free of crevices and bug traps. It is used where CIP (Clean In Place) systems prevail, with the RJT only tending to be used where very regular access is needed.

IDF type couplings comprise four parts – a male part, a liner, a seal ring and a hexagonal or round nut. The ends of the tubes and/or fittings to be joined have a male part and liner fitted by welding (or expansion on to expanded type parts if used). The joint is made by positioning the male part and the liner together, with a seal inserted between. The nut is then slipped over the liner, screwed on to the male part and tightened against the liner to compress the seal.

BS 4825 : Part 3 requirements for IDF union parts follow.

Assembly

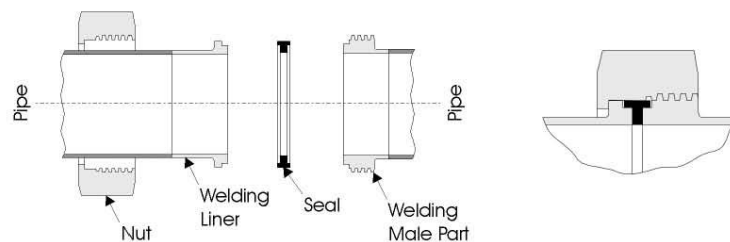

The illustration above shows the assembly of an IDF union with welded parts.

Options:

- Expanded IDF expanded type union parts are available.
- Round nuts. True IDF round nuts have no slots on their circumference, making them tamper proof, but necessitating the use of a special spanner.

Hygienics

IDF Unions - BS 4825 : Part 4

Welding male part (threaded)

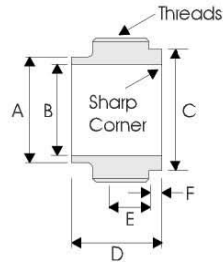

Notes
- An ACME form thread is used.

OD	A	B	C	D	E	F
mm	mm	mm	mm	mm	mm	mm
25.4	25.65	22.2	29.2	21.5	13.5	3.0
38.1	38.35	34.9	42.7	21.5	13.5	3.0
50.8	51.05	47.6	56.2	21.5	13.5	3.0
63.5	63.75	60.3	69.9	21.5	13.5	3.0
76.2	76.45	73.0	82.6	21.5	13.5	3.0
101.6	101.85	97.6	111.1	30.0	16.0	3.2

Welding liner

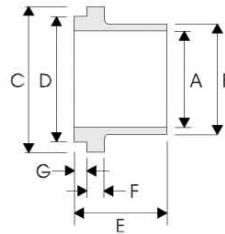

OD	A	B	C	D	E	F	G
mm	mm	mm	mm	mm	mm	mm	mm
25.4	22.2	25.65	33.8	29.2	21.5	4.0	3.0
38.1	34.9	38.35	47.0	42.7	21.5	4.0	3.0
50.8	47.6	51.05	60.5	56.2	21.5	4.0	3.0
63.5	60.3	63.75	74.0	69.9	21.5	4.0	3.0
76.2	73.0	76.45	87.5	82.6	21.5	4.0	3.0
101.6	97.6	101.85	120.6	111.1	30.0	4.75	3.2

Hygienics

IDF Unions - BS 4825 : Part 4

Hexagonal nut

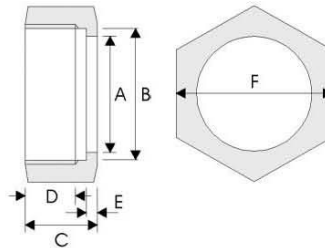

Notes

- An ACME form thread is used.
- A round nut may be specified.

OD	A	B	C	D	E	F
mm	mm	mm	mm	mm	mm	mm
25.4	30.5	34.34	30	16	3.5	46
38.1	43.5	47.86	30	16	3.5	60
50.8	57.0	61.37	30	16	3.5	75
63.5	70.7	74.88	30	16	3.5	90
76.2	83.3	88.40	30	16	3.5	105
101.6	112.0	122.00	35	20	4.7	133

Seals

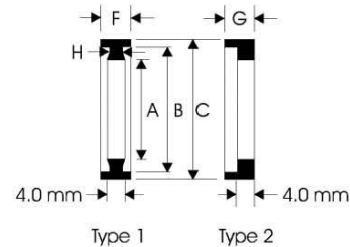

OD	A	B	C	F	G	H
mm	mm	mm	mm	mm	mm	mm
25.4	23.2	29.2	32.5	7.0	6.0	3.0
38.1	35.9	42.7	46.0	7.0	6.0	3.0
50.8	48.6	56.2	59.5	7.0	6.0	3.0
63.5	61.3	69.9	73.2	7.0	6.0	3.0
76.2	74.0	82.6	86.5	7.0	6.0	3.0
101.6	98.6	111.0	119.0	9.6	6.0	5.0

Hygienics

RJT Unions - BS 4825 : Part 5



Ring Joint Type, RJT, unions are easily assembled and dismantled for cleaning purposes, this being a result of their having a Whitworth form thread. The RJT joint is not crevice free and may accumulate a deposit of the product being passed. However, present day cleaning systems are able to sanitise this area successfully without dismantling in the majority of applications. RJT unions may be operated at pressures up to 1.0 MPa.

RJT type couplings comprise four parts – a male part, a liner, an O-ring seal and a hexagonal nut. The ends of the tubes and/or fittings to be joined have a male part and liner fitted by welding (or expansion on to expanded type parts if used). The joint is made by positioning the male part and the liner together, with a seal inserted between. The nut is then slipped over the liner, screwed on to the male part and tightened against the liner to compress the seal.

BS 4825: Part 5 requirements for RJT union parts follow. Additional RJT components are also available (see page 6-11).

Assembly

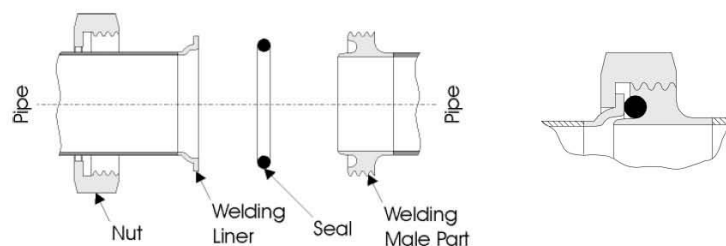

The illustration above shows the assembly of an RJT union with welded parts.
Options:

- Expanded RJT expanded type union parts are available.

Hygienics

RJT Unions - BS 4825 : Part 5

Welding male part (threaded)

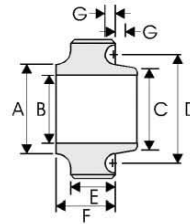

OD	A	B	C	D	E	F	G
mm	mm	mm	mm	mm	mm	mm	mm
25.4	25.65	22.2	25.4	33.3	14.3	21.5	4.8
38.1	38.35	34.9	38.1	46.0	14.3	21.5	4.8
50.8	51.05	47.6	50.8	58.7	14.3	21.5	4.8
63.5	63.75	60.3	63.5	71.4	14.3	21.5	4.8
76.2	76.45	73.0	76.2	84.1	14.3	21.5	4.8
101.6	101.85	97.6	101.6	109.5	14.3	21.5	4.8

Welding liner

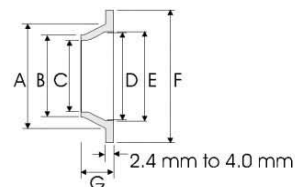

OD	A	B	C	D	E	F	G
mm	mm	mm	mm	mm	mm	mm	mm
25.4	32.5	25.65	22.2	26.2	27.8	41.3	10 or 12.7
38.1	45.2	38.35	34.9	38.9	40.5	54.0	10 or 12.7
50.8	57.9	51.05	47.6	51.6	53.2	66.7	10 or 12.7
63.5	70.6	63.75	60.3	64.3	65.9	79.4	10 or 12.7
76.2	83.3	76.45	73.0	77.0	78.6	92.1	10 or 12.7
101.6	108.5	101.85	97.6	102.4	104	117.5	12.7 or 25.4

Hygienics

RJT Unions - BS 4825 : Part 5

Hexagonal nut

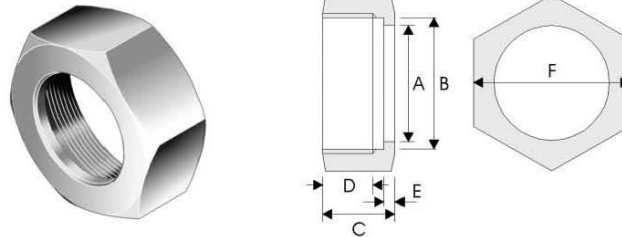

OD	A	B	C	D	E	F
mm	mm	mm	mm	mm	mm	mm
25.4	33.3	46.6	22.2	15.1	4.0	50.8
38.1	46.0	59.3	22.2	15.1	4.0	65.0
50.8	58.7	73.6	22.2	15.1	4.0	79.4
63.5	71.4	86.3	22.2	15.1	4.0	92.1
76.2	84.1	99.0	22.2	15.1	4.0	104.8
101.6	109.5	124.4	22.2	15.1	4.0	130.2

Ring joint seals



OD	A	B
mm	mm	mm
25.4	33.3	6.6
38.1	46.0	6.6
50.8	58.7	6.6
63.5	71.4	6.6
76.2	84.1	6.6
101.6	109.5	6.6

Hygienics

Additional Hygienic Fittings and Components

This subsection covers additional fittings and components that are compatible with the BS 4825 tube and fittings specifications.

Pulled tees

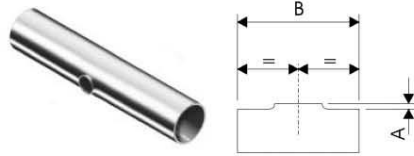

OD	A	B
mm	mm	mm
25.4	2	89
38.1	2	130
50.8	3	178
63.5	3	229
76.2	3	267
101.06	5	348

Reducing tees

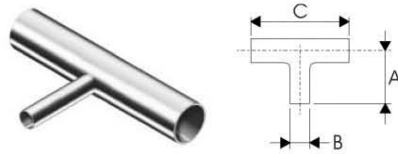

OD	A	B	C
mm	mm	mm	mm
38.1 to 25.4	38	25.4	70
50.8 to 25.4	51	25.4	82
50.8 to 38.1	51	38.1	82
63.5 to 38.1	63.5	38.1	105
63.5 to 50.8	63.5	50.8	105
76.2 to 50.8	76	50.8	110
76.2 to 63.5	76	63.5	110

Hygienics

Additional Hygienic Fittings and Components

Concentric and eccentric reducers

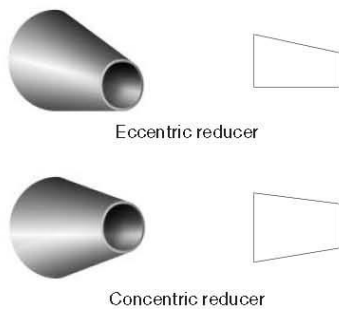

OD mm	Availability	
	Eccentric	Concentric
38.1 to 25.4	✓	✓
50.8 to 38.1	✓	✓
50.8 to 25.4	✓	✓
63.5 to 50.8	✓	✓
63.5 to 38.1	✓	✓
63.5 to 25.4	✓	-
76.2 to 63.5	✓	-
76.2 to 50.8	✓	✓
76.2 to 38.1	✓	✓
76.2 to 25.4	✓	✓
101.6 to 76.2	✓	✓
101.6 to 63.5	✓	-

Notes
- Dimensions are subject to agreement with purchaser

Hinged pipe clip

Two piece hinged pipe clip tightened by an M8 knurled thumb nut and having a BSP threaded boss

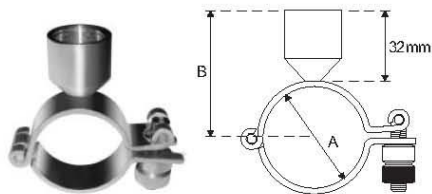

OD in	A mm	B m
1/2	12.7	40
3/4	19.0	40
1	25.4	45
1 1/2	38.1	50
2	50.8	60
2 1/2	63.2	65
3	76.2	70
4	101.6	80

Notes
- Dimensions are subject to agreement with purchaser

Hygienics

Specifications - ASTM A270

Seamless and welded austenitic stainless steel sanitary (hygienic) tubing

This specification covers seamless and welded austenitic stainless steel hygienic tubing having special surface finishes.

Dimensions and tolerances

- **Dimensions.** Tube sizes normally furnished to this specification are ≤4 in (101.6mm) OD.
- **Cut lengths** shall be no less than specified and not more than 1/8 in (3.2mm) over that specified.

Cross-sectional tolerances

Outside Diameter (OD)		Variations in OD				Variation in t	
in	mm	Under		Over		Under	Over
		in	mm	in	mm	%	%
≤1	≤25.4	0.005	0.13	0.005	0.13	12.5	12.5
>1 to 2	>25.4 to 50.8	0.008	0.20	0.008	0.20	12.5	12.5
>2 to 3	>50.8 to 76.2	0.010	0.25	0.010	0.25	12.5	12.5
>3 to 4	>76.2 to 101.6	0.015	0.38	0.015	0.38	12.5	12.5

- Notes
 1 For t<0.049 in (1.24mm) tolerances to be agreed with purchaser.
 2 There are no ovality requirements.

Chemical composition

Grade	UNS	Composition Percentage, Max or Range								Note
		Carbon C	Manganese Mn	Phosphorus P	Sulphur S	Silicon Si	Nickel Ni	Chromium Cr	Molybdenum Mo	
TP304	S30400	0.08	2.00	0.045	0.030	1.00	8.00-11.00	18.00-20.00	-	
TP304L	S30403	0.035	2.00	0.045	0.030	1.00	8.00-12.00	18.00-20.00	-	1
TP316	S31600	0.08	2.00	0.045	0.030	1.00	10.00-14.00	16.00-18.00	2.00-3.00	
TP316L	S31603	0.035	2.00	0.045	0.030	1.00	10.00-14.00	16.00-18.00	2.00-3.00	1

- Notes
 1 Carbon 0.040% max is necessary for tubes where many drawing passes are required, as with outside diameter <0.5 in (12.7mm) or nominal wall thickness <0.049 in (1.2mm) (minimum wall thickness <0.044 in (1.12mm))

BS 4825 Part 1 / EN20286 - dimensions and tolerances

- **O/D Tolerance.** ±0.5% or 0.1mm whichever is the greater.
- **Wall Thickness Tolerance.** ±12.5%.
- **Surface Finish.** Internal 1.0Ra Maximum / External 2.5Ra Maximum.
- **Length.** For lengths up to and including 6 metres +3mm -0mm / For lengths over 6 metres +6mm -0mm.